

*Faster, stronger, heavier & first of all safer!*

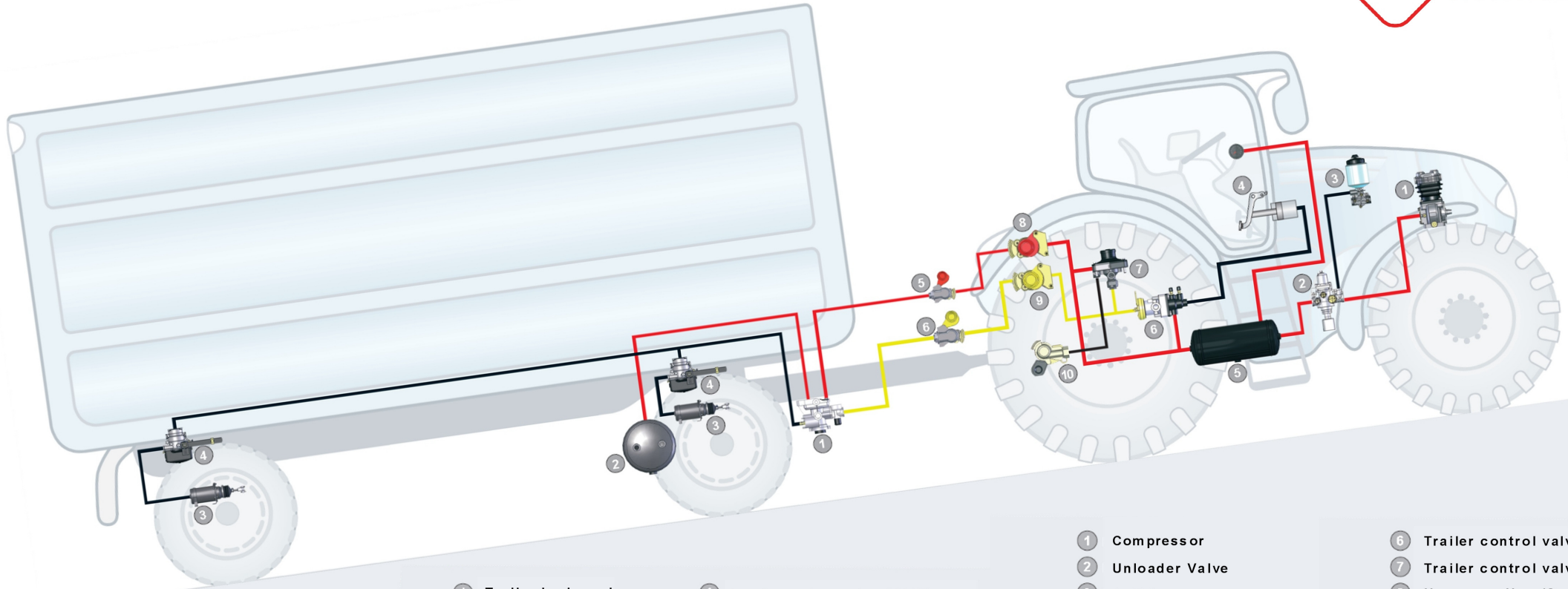

- |                       |  |                                    |                                |
|-----------------------|--|------------------------------------|--------------------------------|
| 1 Trailer brake valve | 4 Load sensing valve (ALB)               | 1 Compressor                       | 6 Trailer control valve 2-line |
| 2 Air reservoir       | 5 Hose coupling with line filter(Supply) | 2 Unloader Valve                   | 7 Trailer control valve 1-line |
| 3 Brake cylinder      | 6 Hose coupling with line filter (Brake) | 3 Anti freeze pump                 | 8 Hose coupling (Supply)       |
|                       |  | 4 Pedal with master brake cylinder | 9 Hose coupling (Brake)        |
|                       |  | 5 Air reservoir                    | 10 Hose coupling (1-line)      |

[www.atzlinger.at](http://www.atzlinger.at)